

F18 - 3U CompactPCI®/Express Core 2 Duo SBC

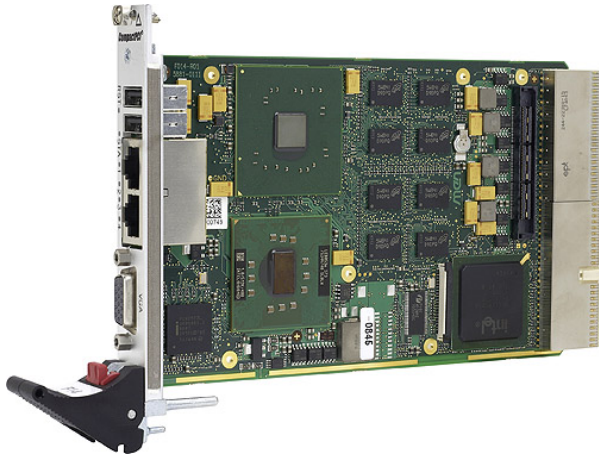

Equipped with the Intel® high-performance Core 2 Duo processor T7500 running at 2.2 GHz, the F18 is a versatile 4HP/3U (single-slot, single-size Eurocard) single-board computer based on the latest multi-core processor architecture from Intel® with full 64-bit support. The board delivers an excellent graphics performance and is designed especially for embedded systems which require high computing performance with low power consumption.

The F18 offers a 32-bit/33-MHz CompactPCI® bus interface and can also be used without a bus system. In combination with a specific side card it can also perform system-slot functionality in a CompactPCI® Express system.

A total of six PCI Express® lanes for high-speed communication (such as Gigabit Ethernet, graphics) are supported on the F18. 2 x1 PCIe® links are used for the two onboard Ethernet interfaces. 4 x1 or 1 x4 PCIe® links are available on a specific side card. The DDR2 DRAM is soldered to F18 to guarantee optimum shock and vibration resistance. A robust IDE CompactFlash® device offers nearly unlimited space for user applications. In addition to parallel ATA, three serial ATA lines are available.

The standard I/O available at the front panel of F18 includes graphics on a VGA connector, two PCIe®-driven Gigabit Ethernet interfaces as well as two USB 2.0 ports.

The F18 can be extended by different side cards.

- Intel® Core™ 2 Duo T7500, 2.2 GHz
- Dual core 64-bit processor
- Full 64-bit support (4 GB memory addressable)
- PCI Express® six x1 links
- 4 HP system master or stand-alone
- 32-bit CompactPCI® or cPCI Express®
- Up to 4 GB DDR2 DRAM soldered
- CompactFlash® slot
- 3 SATA interfaces
- Video via VGA and 2 SDVO
- 2 Gigabit Ethernet (PCIe®)
- Up to 8 USB 2.0
- High Definition audio
- Board controller

Additional functions include two digital video inputs for flat panel connection via DVI (multimedia), a variety of different UARTs or another four USB 2.0 ports, SATA for hard disk or RAID connection and HD audio. The F18 is also prepared for rear I/O where for example another two USB 2.0 ports can be connected. Two watchdogs for thermal supervision of the processor and board temperature as well as for monitoring the operating system complete the functionality of the F18. The F18 operates in Windows® and Linux environments as well as under real-time operating systems that support Intel®'s multi-core architecture. The Award BIOS was specially designed for embedded system applications.

Equipped with Intel® components exclusively from the Intel® Embedded Line, the F18 has a guaranteed minimum standard availability of 5 years.

The F18 is suited for a wide range of industrial applications, e.g. for monitoring, vision and control systems as well as test and measurement. Main target markets comprise industrial automation, multimedia, traffic and transportation, aerospace, shipbuilding, medical engineering and robotics.

The F18 comes with a tailored passive heat sink within 4 HP height. Anyhow, forced air cooling is always required inside the system. The robust design of the F18 make the board especially suited for use in rugged environments with regard to shock and vibration according to applicable DIN, EN or IEC industry standards. The F18 is also ready for coating so that it can be used in humid and dusty environments.

Technical Data

CPU

- Intel® Core™ 2 Duo T7500
 - Dual-core 64-bit processor
 - 2.2GHz processor core frequency
 - Up to 800MHz front-side bus frequency
- Chipset
 - Northbridge: Intel® 965GME Express
 - Southbridge: Intel® ICH8M-E (Enhanced)

Memory

- 4MB L2 cache integrated in Core 2 Duo
- Up to 4GB SDRAM system memory
 - Soldered
 - DDR2
 - 667MHz memory bus frequency
 - Dual-channel, 2x64 bits
- 8Mbits boot Flash
- Serial EEPROM 2kbits for factory settings
- CompactFlash® card interface
 - Via onboard IDE
 - Type I
 - True IDE
 - DMA support

Mass Storage

- Parallel IDE (PATA)
 - One IDE port for local CompactFlash®
- Serial ATA (SATA)
 - Two channels via side-card connector, up to two channels via rear I/O (optional)
 - Transfer rates up to 150MB/s
 - RAID level 0/1 support

Graphics

- Integrated in 965GME Express chipset
 - Up to 500MHz 256-bit graphics core
 - Maximum resolution: 2048 x 1536 pixels @ 60Hz, 32bpp reduced blanking timing (driver limited)
- VGA connector at front panel
- Two SDVO ports available via side-card connector
 - Two additional DVI connectors at front panel optional via side card
 - Simultaneous connection of two monitors

I/O

- USB
 - Two USB 2.0 ports via Series A connectors at front panel
 - Four USB 2.0 ports via side-card connector
 - Two USB 2.0 ports via rear I/O on request
 - UHCI implementation
 - Data rates up to 480Mbits/s

- Ethernet
 - Two 10/100/1000Base-T Ethernet channels
 - RJ45 connectors at front panel
 - Ethernet controllers are connected by two x1 PCIe® links
 - Onboard LEDs to signal activity status and connection speed
- High Definition (HD) audio
 - Accessible via side-card connector

Front Connections (Standard)

- VGA
- Two USB 2.0 (Series A)
- Two Ethernet (RJ45)

Miscellaneous

- Board controller
- Real-time clock, buffered by a GoldCap or alternatively a battery (5 years life cycle)
- Watchdog timer
- Temperature measurement
- One user LED
- Reset button

PCI Express®

- Two x1 links to connect local 1000Base-T Ethernet controllers
 - Data rate 250MB/s in each direction (2.5 Gbits/s per lane)
- One x4 or four x1 links for extension through side-card connector
 - Data rate up to 1GB/s in each direction (2.5 Gbits/s per lane)

CompactPCI® Bus

- Compliance with CompactPCI® Core Specification PICMG 2.0 R3.0
- CompactPCI® Express support (EXP.0 R1.0)
- System slot
- 32-bit/33-MHz CompactPCI® bus
- V(I/O): +3.3V (+5V tolerant)

Busless Operation

- Board can be supplied with +5V only, all other voltages are generated on the board
- Backplane connectors used only for power supply

Electrical Specifications

- Supply voltage/power consumption:
 - +5V (-3%/+5%), 9A typ., if the F18 is operated with 5V only, the 3.3V voltage can be used to supply other CompactPCI® boards in the system, maximum load: 10W

Technical Data

- +3.3V (-3%/+5%), 1.8A (2 Gb Ethernet), 1.3A (1 Gb Ethernet)
- +12V (-10%/+10%), approx. 10mA
- MTBF: 238,053h @ 40°C according to IEC/TR 62380 (RDF2000)

Mechanical Specifications

- Dimensions: conforming to CompactPCI® specification for 3U boards
- Front panel: 4HP with ejector
- Weight: 420g

Environmental Specifications

- Temperature range (operation):
 - 2.2GHz Core 2 Duo T7500: 0..+60°C
 - Conditions: airflow 1.5m/s, typical power dissipation 38W, with Windows® XP operating system, 1 Gb Ethernet and hard disk, without CPU clock reduction
- Temperature range (storage): -40..+85°C
- Relative humidity (operation): max. 95% non-condensing
- Relative humidity (storage): max. 95% non-condensing
- Altitude: -300m to + 2,000m
- Shock: 15g/11ms
- Bump: 10g/16ms
- Vibration (sinusoidal): 1g/10..150Hz
- Conformal coating on request

Safety

- PCB manufactured with a flammability rating of 94V-0 by UL recognized manufacturers

EMC

- Tested according to EN 55022 (radio disturbance), IEC1000-4-2 (ESD) and IEC1000-4-4 (burst)

BIOS

- Award BIOS

Software Support

- Note that 64-bit hardware technology requires 64-bit operating system support
- Windows® (including Vista)
- Linux
- VxWorks® (on request)
- QNX®
- Intel® Virtualization Technology, allows a platform to run multiple operating systems and applications in independent partitions; one computer system can function as multiple "virtual" systems
- For more information on supported operating system versions and drivers see Software.

Diagram

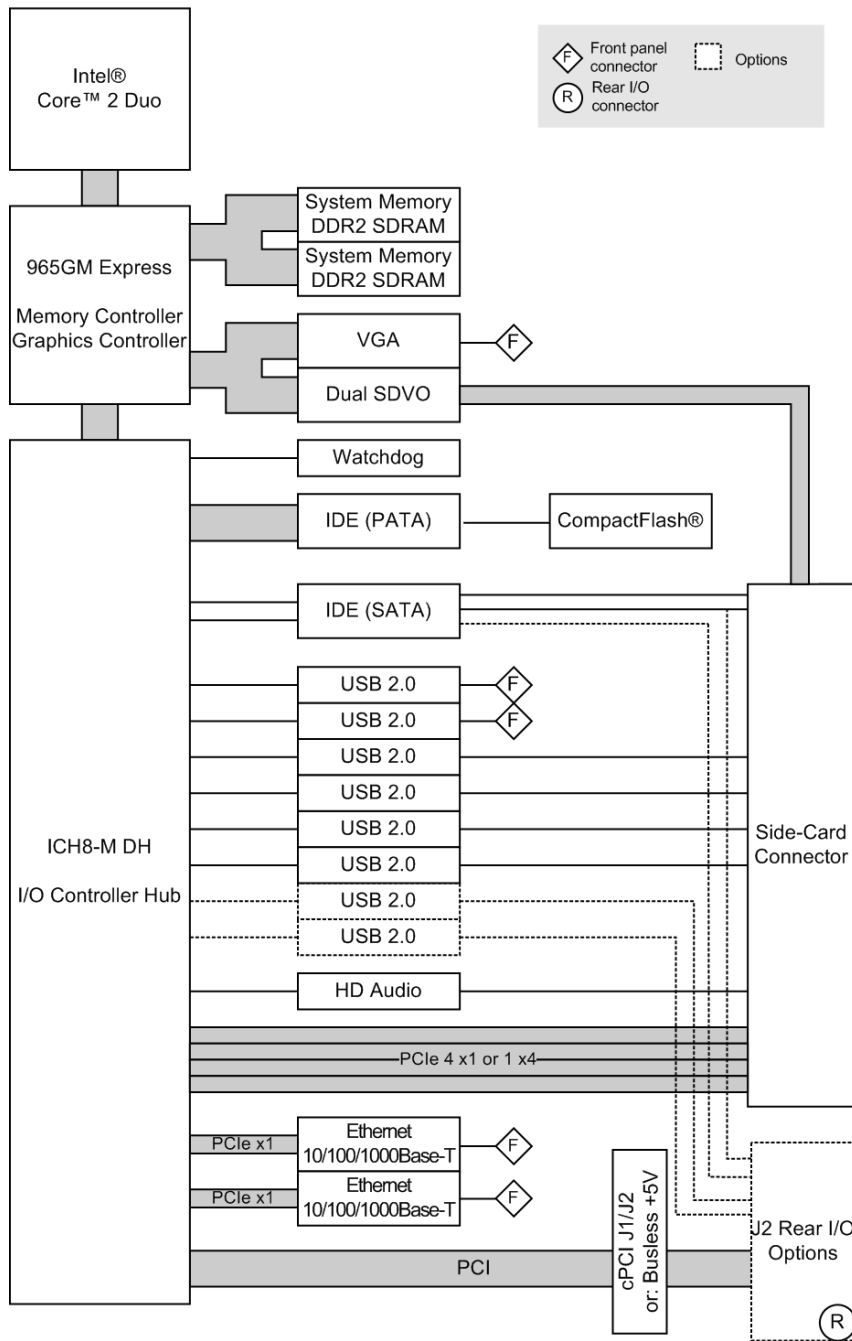

Configuration & Options

Standard Configurations

Article No.	CPU Type	Clock	System RAM	CFlash	Side Card Slot	Operation Temperature
02F018-00	T7500	2.2 GHz	4 GB	0 MB	right	0..+60°C

Options

CPU

- Core 2 Duo T7500, 2.2GHz (35W)
- Core 2 Duo L7500 1.6 GHz (17W)
- Core 2 Duo U7500 1.06GHz (10W)

Memory

- System RAM
 - 256 MB, 512 MB, 1 GB, 2 GB or 4 GB
- CompactFlash®
 - 0 MB up to maximum available

Graphics

- One or two DVI-D connectors at front via side card
 - Simultaneous connection of two monitors

I/O

- Ethernet
 - 9-pin D-Sub connector with one or two 10/100Base-T ports instead of two RJ45 connectors

Rear I/O

- Two SATA channels (third SATA channel via side-card connector)
- Two USB 2.0 ports

Mechanical

- Side card can be added at left or right side of CPU

Operation Temperature

- Depends on system configuration (CPU, hard disk, heat sink...)
- Maximum: +60°C
- Minimum: -40°C (all processors)

Please note that some of these options may only be available for large volumes. Please ask our sales staff for more information.

Ordering Information

Standard Hardware

- 02F018-00** Intel Core 2 Duo T7500, 2.2 GHz, 4 GB DDR2 DRAM, 2 Gigabit Ethernet, 0..+60°C
- 02F018-03** Intel Core 2 Duo T7500, 2.2 GHz, 2 GB DDR2 DRAM, 2 Gigabit Ethernet, 0..+60°C

Related Hardware

- 02F600-00** 2 COM extensions and SATA hard disk slot, for F14 and compatible SBCs, -40..+85°C screened
- 02F601-00** 1 DVI-D and 1 audio at front, SATA hard disk slot, for F14 and compatible SBCs, 4HP, 0..+60°C
- 02F601-02** 2 DVI-D, 1 audio, 1 COM (via SA-Adapter) at front, SATA hard disk slot, for F14 and compatible SBCs, 8HP, 0..+60°C
- 02F602-00** 3U CompactPCI to CompactPCI Express side card with 1 USB, 1 COM, 1 DVI, SATA hard disk slot, for F14 and compatible SBCs, 0..+60°C
- 02F603-00** 3U CompactPCI side card with 2 USB and 1 COM extension, SATA hard disk and CompactFlash slot, for F14 and compatible SBCs, mounted to the right of the SBC, 0..+60°C
- 02F604-00** 3U CompactPCI side card with 1 IEEE 1394 FireWire, 1 DVI, 1 HD audio and 1 COM extension, SATA hard disk slot, for F14 and compatible SBCs, mounted to the right of the SBC, 0..+60°C
- 02F605-00** 1 XMC or PMC slot, for F14 and compatible SBCs, -40..+85°C with qualified components
- 02F606-00** 2 Gigabit Ethernet on Lemo railway compliant connectors, 1 COM extension (SA-Adapter not included), SATA hard disk slot, for F14 and compatible SBCs, conformally coated, -40...+85°C screened
- 02F608-00** 4 SATA and 2 COM ports, additional SATA hard disk slot on-board, for F14 and compatible SBCs, mounted to the right of the SBC, 0..+60°C

Memory

- 0751-0032** CompactFlash card, 8 GB, Type I, -40..+85°C, fixed bit set
- 0751-0038** CompactFlash card, 256 MB, Type I, removable, -40..+85°C

- 0751-0039** CompactFlash card, 512 MB, Type I, removable, -40..+85°C
- 0751-0040** CompactFlash card, 1 GB, Type I, fixed bit set, -40..+85°C
- 0751-0041** CompactFlash card, 2 GB, Type I, fixed bit set, -40..+85°C
- 0751-0042** CompactFlash card, 4 GB, Type I, fixed bit set, -40..+85°C

Systems & Card Cages

- 0701-0041** 19" 4U/84HP CompactPCI Express rack-mount enclosure, 8-slot hybrid backplane, space for hard-disk drives, CD-ROM drive, 300W ATX PSU, 1U fan tray with 2 fans included
- 0701-0046** CompactPCI 19" 4U/24HP desktop system for 3U cards, 3-slot 3U CompactPCI backplane, system slot right, 1U fan tray with 1 fan, 8 HP space for 1 pluggable PSU
- 0701-0056** CompactPCI 19" 4U/84HP rack-mount enclosure for 3U cards (vertical), 4+4-slot 3U CompactPCI / CompactPCI Serial hybrid backplane, prepared for rear I/O, 250W power supply wide range 90..264VAC on rear, 1U fan tray with 2 fans included, 0..+60°C

Miscellaneous

- 0713-0003** CompactPCI 3U 1-slot backplane for stand-alone operation of F14, F15, F17, F18, F19P: 32-bit/33-MHz with rear I/O, 3.3V supply, ATX-power, power, JTAG, IPMB and utility connection, 6x screw connection M3

Software: OS independent

- 13Y001-06** MDIS5 low-level driver sources (MEN) for LM63 on SMBus for F14, F15, F17, F18, D9, D601, A19 and A20
- 13Y002-06** MDIS5 low-level driver sources (MEN) for F14, F15, F17, F18, D9, D601, A19 and A20 board monitoring
- 13Y004-06** MDIS5 low-level driver sources (MEN) for generic SMBus driver for F14, F15, F17, F18, F19P, D9, D601, F600 and F601, A19, A20 and F217
- 13Y007-06** MDIS5 low-level driver sources (MEN) for F14, F15, F17, F18, D9, D601, A19 and A20 board controller

Ordering Information

Software: Windows

- 10F014-78** Windows Embedded Standard BSP (MEN) for F14, F15, F17, F18, F19P, G20, XM1, XM1L, XM2, MM1, SC21, DC1 and RC1
- 13F014-77** Windows Installset (MEN) for F14, F15, F17, F18, D9, D601, A19 and A20
- 13T001-70** Windows network driver (Intel) for F14, F15, F17, F18, D9, D6, D7, D601, A19, A20 and P601, P602
- 13T003-70** Windows chipset driver (Intel) for F14, F15, F17, F18, F18E, F19P, D9, D6, D7, D601, A19 and A20
- 13T005-70** Windows USB2UART driver (FTDI) for F14, F15, F17, F18, F19P, D9, A19, A20, XM2 and XM50 hosts
- 13T006-70** Windows HD Audio driver (Realtek) for F14, F15, F17, F18, D9 and A19
- 13T008-70** Windows chipset graphics driver (Intel) for F18
- 13T010-70** Windows 32-bit network driver (Intel) for XM1, XM1L, XM2, F11S, F18, F18E, F19P, G20, G211 and D7
- 13T020-70** Windows 64-bit network driver (Intel) for F18, F18E, F19P, G20, G211, XM2 and D7

Software: VxWorks

- 13Y003-60** VxWorks driver (MEN) for USB-to-UART bridges on F600, F601, F602, F603, F604, F606 and D700

Software: QNX

- 10F014-40** QNX 6.3.0 BSP (QNX and MEN) for F14, F15, F17, F18, F19P, XM1, XM2 and MM1

Software: Firmware/BIOS

- 14F018-00** System BIOS for F18

Documentation

- 20APPN004** Application Note: How to make a USB stick bootable
- 20F018-00** F18 User Manual

Contact Information

Germany

MEN Mikro Elektronik GmbH
 Neuwieder Straße 5-7
 90411 Nuremberg
 Phone +49-911-99 33 5-0
 Fax +49-911-99 33 5-901
 E-mail info@men.de
 www.men.de

France

MEN Mikro Elektronik SA
 18, rue René Cassin
 ZA de la Châtelaine
 74240 Gaillard
 Phone +33 (0) 450-955-312
 Fax +33 (0) 450-955-211
 E-mail info@men-france.fr
 www.men-france.fr

USA

MEN Micro, Inc.
 24 North Main Street
 Ambler, PA 19002
 Phone (215) 542-9575
 Fax (215) 542-9577
 E-mail sales@menmicro.com
 www.menmicro.com

The date of issue stated in this data sheet refers to the Technical Data only. Changes in ordering information given herein do not affect the date of issue.

All brand or product names are trademarks or registered trademarks of their respective holders.

Information in this document has been carefully checked and is believed to be accurate as of the date of publication; however, no responsibility is assumed for inaccuracies. MEN Mikro Elektronik accepts no liability for consequential or incidental damages arising from the use of its products and reserves the right to make changes on the products herein without notice to improve reliability, function or design. MEN Mikro Elektronik does not assume any liability arising out of the application or use of the products described in this document.

The products of MEN Mikro Elektronik are not suited for use in nuclear reactors or for application in medical appliances used for therapeutical purposes.

Application of MEN's products in such plants is only possible after the user has precisely specified the operation environment and after MEN Mikro Elektronik has consequently adapted and released the product.

Copyright © 2010 MEN Mikro Elektronik GmbH. All rights reserved.